



CM-500A

Wrist Strap Constant Monitor



IMPORTANT!! READ THIS MANUAL BEFORE OPERATING THIS UNIT.

CM-500A

WRIST STRAP CONSTANT MONITOR

- Constantly Monitors Operator Resistance to Ground
- Each Unit Supports 2 Operators
- Dual Grounding Method Provides Redundant Protection
- Offers the Ultimate Protection from Faulty Grounding
- Rugged All Metal Construction with Mounting Bracket

The Pinion Products Corporation Wrist Strap Constant Monitor model CM-500A enables constant resistive monitoring of an operator's resistance to ground. The CM-500A supports 2 operators with distinct controls and indicators. The unit is AC powered and is operated simply by wearing a dual lead wrist strap and turning on the CM-500A unit. The CM-500A tests that the resistance to ground of the operator is within a proper range. The upper limit tests whether static is being effectively dissipated. The lower limit is required to limit the discharge current from a device or board, and for reasons of personnel safety. The unit is connected to earth ground through the outlet the AC adapter is plugged into, and through a separate jack, allowing the wrist strap to be grounded through the unit and thus eliminating messy wiring to ground the unit and the wrist strap. The wrist straps are grounded through the separate jack, and not the AC outlet. The dual grounds are continuously monitored so that if one of them is disconnected it will be detected and the unit will indicate a fault condition.

Operating Instructions

The CM-500A should be located on or near a work station, with the AC Adapter plugged into a standard 120VAC 3 prong grounded outlet with the adapter output into the jack on the rear of the unit and the rear earth ground jack connected to earth ground. To use the CM-500A, the operator attaches their dual lead wrist strap to the two sets of connections (labeled WRIST) and turns on the corresponding switch. The operator's resistance to ground is now continuously monitored. The green light and absence of an alarm tone indicates that the operator is grounded effectively. The amber light and alarm indicate a resistance to ground greater than the upper resistance limit. The red light and alarm indicate the resistance to ground is below the lower resistance limit. The amber light and alarm will also come on if either of the ground connections come loose.

Mounting Instructions

The unit can be used freestanding or mounted on top or under the workbench. The operator ground connection and the DC power connectors are on the rear of the unit and spacing must be allowed behind the unit for the connections. If the ground cable is used as received (with banana plug) a minimum of 1.75 inches behind the unit is required and it is plugged into the threaded opening next to the power jack. If the optional screw/lug method is used, 1" minimum is necessary and you must cut off the banana plug, crimp or solder the supplied lug to the wire and secure to the rear of the unit with the 10-32 screw and lock washer also supplied. Mount bracket with the open side against the bench with 4.1" inside spacing or 2.75" between the mounting holes (insure unit will slide into bracket before tightening screws). See drawing. Screws not supplied. The spacing between the mounting screws and any rear obstruction must be at least 2.75" or 3.5" (depending upon grounding method). Inserting screwdriver through large holes in the bracket can tighten screws.

For freestanding use attach supplied rubber feet to base.

Wrist Strap Features

The CM-500A dual lead wrist strap is essentially two separate wrist straps in one, separated by an isolating border. This allows for a completely resistive measurement, similar to the operation of the WSST-300 unit.

The user can wear two separate wrist straps (if another type of wrist strap is preferred) and connect them to the CM-500A, and achieve the same constant monitor function.

The dual strap technique allows the test voltage to come out on one lead, create a current that flows through the skin, and return to ground via the second lead. True resistive testing provides a more accurate and consistent check of the wrist strap, wrist strap cord, and wrist strap to operator connection.

Troubleshooting

Most apparent problems with the CM-500A can be traced to improper electrical connections or poor skin to strap contact by the wrist strap.

If test results seem to be wrong, the CM-500A or the grounding arrangement may not be connected properly (See Operating Instructions above). The CM-500A is grounded through the outlet the AC adapter is plugged into and the separate earth ground jack on the rear of the unit. Both connections must be made

to the same earth ground reference for the unit to signal OK. The wires used for making these connections should be checked for continuity, or a specified resistance, as with a wrist strap cord. The work surface connections and wire should also be checked.

Insufficient skin to wrist strap contact can cause a “high resist” failure. This type of failure mode is more prevalent with hairier arms or dry skin. In both cases, commercially available conductive hand cream lotions are recommended to be applied to the wrist before attaching the wrist strap. These lotions are specifically designed for this purpose.

Specifications

Parts Included:

Qty	Part
1	CM-500A unit
1	AC adapter
1	ground cord
1	Mounting bracket with 2 spacers and 2 screws to attach to unit only
1	Hardware set for optional grounding method with screw and lug
4	Rubber feet for freestanding operation

Resistance tolerances:

The CM-500 uses a dual lead wrist strap to monitor the operator’s resistance to ground. The resistance measured includes the resistance between the monitor point and the operator, with the operator tied to ground through the monitor point. The effective operator resistance being checked is different from the total loop resistance being checked. The upper limit for the operator’s effective resistance to ground is 10 megohms. The actual resistance limits are as listed under “Calibration Check” do not include an internal resistance to ground of 1 megohm:

Power:

120VAC, 60Hz, (3 pronged grounded plug) input to AC adapter with 12VDC, 50ma,
Output (-/GND lead from adapter connected to ground pin on AC adapter)

Wrist Strap Test Voltage: 7.6 volts nominal

Optional Wrist Strap 1 meg ohm nominal in each wire of the cord

Cord Resistance:

Available Accessories:

- Dual lead wrist strap (Available in Small, Medium & Large)
- Dual lead wrist strap cord (Available in 6, 10, 12 & 20 foot lengths)
- Replacement ground cord

Calibration Check

The calibration of the constant Monitor should be checked annually using the procedure defined here. Using the specified resistance values for each of the three limit tolerance values, the test results indicate whether the unit is operating properly. The resistance values to be used and test results are listed below. Perform the test by connecting the resistance values between the appropriate operator jacks within the proper power switch turn on.

Operator:	Lower Limit (1.3 Mohm)	1.17 Mohm \pm 1% Red LED with tone
		1.43 Mohm \pm 1% Green LED with NO tone
	Upper Limit (39 Mohm)	33.15 Mohm \pm 1.5% Green LED with NO tone
		44.85 Mohm \pm 1.5% Amber LED with tone

Contact Pinion Products Corporation for information on replacement accessories or other Pinion products.

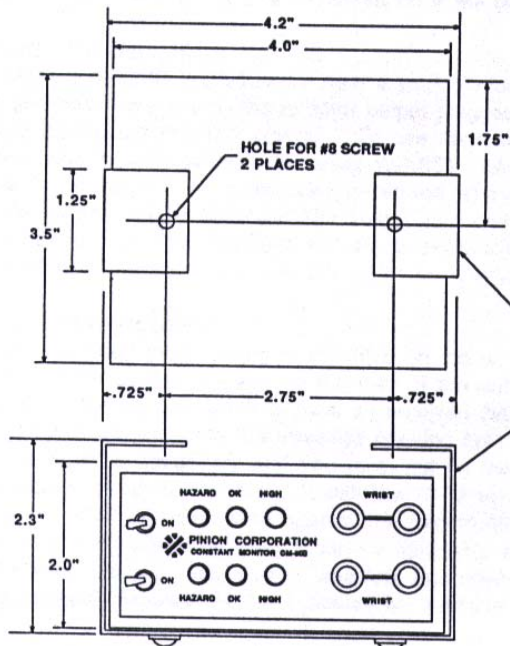
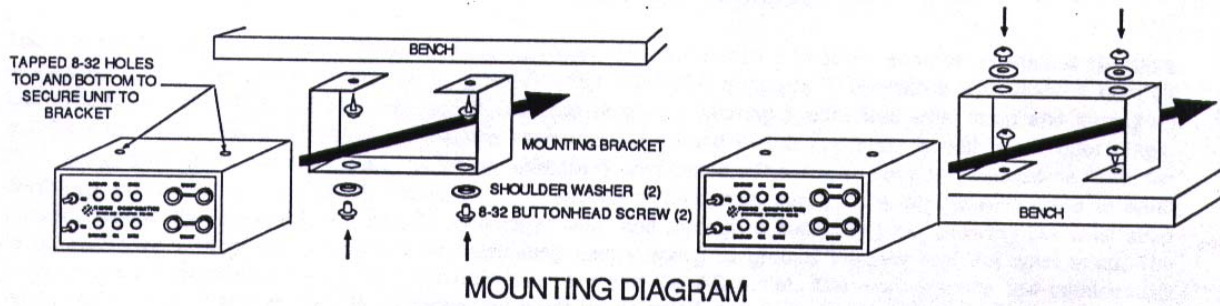

PHYSICAL DIMENSIONS

REQUIRES MINIMUM OF 1 INCH CLEARANCE ON REAR OF UNIT FOR POWER CONNECTOR WHEN GROUNDING WITH SCREW AND LUG OR 1.75 INCHES WHEN GROUNDING WITH BANANA PLUG.

MOUNTING BRACKET

GROUND JACK ACCEPTS BANANA PLUG OR 10-32 SCREW WITH LUG (SUPPLIED)

REAR VIEW

