



INSTRUCTION MANUAL – COMBINATION RESISTIVITY METER, MODEL SRM/RTG



IMPORTANT!! READ THIS MANUAL BEFORE OPERATING THIS UNIT.

THEORY OF OPERATION

The Pinion/Voyager model SRM/RTG Combination Surface Resistivity meter is a simple to use, highly repeatable measuring device for determining the surface resistivity of materials, as well as resistance to ground. The SRM/RTG incorporates a revolutionary three-point probe measuring technique, enabling accurate, consistent, and repeatable surface measurements. The principle of operation is as follows:

A voltage, V (30 Volts), is applied to each of the three outer probe contacts (Figure 1).

The center probe contact (spring loaded) provides a ground return of the current supplied by the three outer probe contacts. The surface resistivity of the material being measured is expressed as ten to some power, written as Ohms/Square = 10^x ; where "x" is rounded to the nearest integer by the SRM/RTG with the following exceptions: The 10^5 range covers 10^4 to $10^{5.5}$. This allows the first display segment to indicate surface resistivities less than 10^4 Ohms/Square.

By studying the relationship between the outer probe contacts and the center probe contact, the following is evident: The diameter of the probe contact is 1/8 inch, and the distance from the outer contact to the center probe is 1-1/2 inches. The approximate number of squares for a 1/8-inch strip of material between the center probe and one of the outer probes is 12 (Figure 2). Three 12 square areas configured in parallel yield a 4 square resultant area (Figure 3). The configuration in Figure e however still does not accurately include the entire area measured by the SRM/RTG probe arrangement. A more representative depiction of current flow includes the entire circular area (Figure 4). There are more paths in parallel further reducing the number of squares. The resulting number of squares was experimentally determined to be 0.78. Experimental data was taken to determine the effect of fringe current that exists outside the circular area encompassed by the probe arrangement. These fringe affects were measured to be less than 1% (Figure 5). The conductive elastomer probe contacts provide excellent contact to the surface under test. For this reason, great pressure is not needed to perform a measurement. Each probe contact of the SRM/RTG applies a pressure of 40 lbs/in², due to the 2 pound weight of the SRM/RTG, which is sufficient. The three-point probe design enables the unit to be balanced on irregular and curved surfaces.

SPECIFICATIONS:

<u>Display Segment</u>	<u>Resistance Range (Ohms/Square)</u>
10 ⁴	<10 ⁴
10 ⁵	10 ^{4.4} – 10 ^{5.5}
10 ⁶	10 ^{5.5} – 10 ^{6.5}
10 ⁷	10 ^{6.5} – 10 ^{7.5}
10 ⁸	10 ^{7.5} – 10 ^{8.5}
10 ⁹	10 ^{8.5} – 10 ^{9.5}
10 ¹⁰	10 ^{9.5} – 10 ^{10.5}
10 ¹¹	10 ^{10.5} – 10 ^{11.5}
10 ¹²	10 ^{11.5} – 10 ^{12.5}
10 ^{12.5}	>10 ^{12.5}

Accuracy: Indicated exponent +/- .3

Power supply: Rechargeable NiCad or NiMH batteries (2 x 2.4volt packs).

Test Voltage: 30 Volts +/- 2 Volts current limited to 2 mA.

Contact Area: 0.0123 sq in/probe

Contact Pressure: 40-lbs/sq in/probe.

Contact material: Conductive rubber.

Dimensions: 3"H x 4"D x 5" W

Weight: 2 pounds

Calibration Procedure:

The SRM/RTG should be calibrated annually. If any step fails as per the following instructions, the unit should be returned to Pinion Products Corporation Inc. for repair and calibration. Pinion Products Corporation Inc. can provide either a standard NIST Calibration with certification traceable to NIST and after calibration data, or a MIL calibration with certification traceable to NIST and both before and after calibration data.

- 1.) The batteries should be charged before beginning the calibration procedure.

- 2.) Remove the 4 screws, two each side, from the unit, and set the cover to the side. Leave the wires attached so that there is access to the printed circuit board. Turn the unit "ON".
- 3.) All voltage measurements are made relative to the unit ground. The test point for ground is adjacent to the -15 and +15 volt test points.
- 4.) Use a 4-½ digit digital voltmeter such as a Keithley Model 175 Multimeter to measure the voltage on the 30VTP. Record this voltage as V30.
- 5.) Measure and record the voltage at the +15V test point as V15.
- 6.) Calculate and record I(ref) using the formula: $I(\text{ref}) = V30 * .04054$
- 7.) Calculate and record R (tp1) using the formula $R(\text{tp1}) = (V15 - .236) / (I(\text{ref}))$.
- 8.) Calculate and record I(O) using the formula $I(O) = I(\text{ref}) * 1.016$, (exponent -3)
- 9.) Calculate and record I(6) using the formula $I(6) = I(\text{ref}) * .992$, (exponent -9)
- 10.) Turn the unit off and remove the shorting jumper connected to TP1 and its adjacent pin. Measure the resistance between the +15V test point and TP1 lead closest to R7. Adjust P1 until the measured resistance is equal to the calculated value $R_{TP1} \pm 1\%$.
- 11.) Replace the jumper on TP1 and the adjacent pin. Turn the unit on. Connect a current source (e.g. Keithley Model 220) to the side of R6 connected to the large round pad in the center of the board. Apply a current equal to the calculated I (O). Measure the voltage on the test pin marked "OUT" and adjust P2 until the measured voltage is 0.000 VDC +/- .050 VDC.
- 12.) Apply a current equal to calculated value I(6) to the same point as in step 11. Measure the voltage on the test pin marked "OUT", and adjust P3 until the measured voltage is 6.000 VDC +/- .050 VDC.
- 13.) Apply a current equal to .003⁻⁹ amperes. Measure the voltage on the test pin marked "OUT", and adjust P6 for a reading of 8.5 VDC +/- .05VDC. The 10^{12.5} led should be illuminated.
- 14.) Apply a current equal to .03⁻⁹ amperes. Measure the voltage on the test pin marked "OUT", and verify a reading of approximately 7.5 VDC. The 10¹² led should be illuminated.
- 15.) Measure the voltage on the pin marked +8.000 VDC and adjust P4 for a reading of 8.000 VDC +/- .050 VDC.
- 16.) Measure the voltage on the pin marked -2.000 VDC and adjust P5 for a reading of -2.000 VDC +/- .050 VDC.
- 17.) The calibration procedure is now complete. Place the cover back on the base and replace the screws.

Operating Instructions:

DO NOT operate the SRM/RTG with the battery charger connected. The charger will introduce electrical noise which will render readings inaccurate.

Turn off the SRM/RTG when it is not being used, and charge ONLY with the supplied charger when the Low Battery indicator is illuminated, or at the end of the day's use. Charge for a minimum of 12 hours. Do NOT leave the charger connected continuously.

SRM mode

- 1.) The SRM/RTG is extremely easy to operate. Simply turn the unit on in the "SRM" mode, and place it on the surface to be measured. The illuminated display segment indicates the resistivity on the surface being measured. To insure accurate readings, place small or thin samples on non-conductive surfaces (> 10¹⁴ ohms/sq). Ideally, a clean glass surface.
- 2.) Measurements in the 10¹¹ to 10^{12.5} may require a few seconds for the illuminated display to stabilize.

RTG Mode

- 1.) Connect the supplied cable from the black banana jack on the rear of the unit to your ESD ground connection, turn the unit on in the "RTG" mode, and place it on the surface to be measured and read the display.
- 2.) Measurements in the 10¹¹ to 10^{12.5} may require a few seconds for the illuminated display to stabilize.
- 3.) The indicated reading will be resistance to ground readings.
- 4.) If grounding cable is not connected to a proper ground, several LEDs in the display may illuminate. This is normal.

Calibration Check:

- 1.) This is a “Quick” calibration check to verify the SRM/RTG is performing within tolerance.
- 2.) Connect a voltmeter between each of the three outer probe contacts relative to ground (one at a time). The voltage should equal 30V +/- 2 V at each probe.
- 3.) Connect a programmable current source to the center probe contact and ground of the SRM/RTG.
- 4.) Apply the currents in the following table and check that the appropriate display segment is illuminated.

Current (Amperes)	Display Segment	Tolerance
$1.45 * 10^{-3}$	<10 ⁴	1%
$4.95 * 10^{-4}$	10 ⁵	1%
$3.77 * 10^{-5}$	10 ⁶	1%
$3.84 * 10^{-6}$	10 ⁷	1%
$3.85 * 10^{-7}$	10 ⁸	1%
$3.85 * 10^{-8}$	10 ⁹	1%
$3.85 * 10^{-9}$	10 ¹⁰	1%
$3.85 * 10^{-10}$	10 ¹¹	1%
$3.85 * 10^{-11}$	10 ¹²	1%
$6.00 * 10^{-12}$	10 ^{12.5}	35%

- 5.) The calibration check is now complete. If any step failed, the SRM/RTG requires calibration. Please notify Pinion Products Corporation Inc. that the SRM/RTG failed its calibration check, and information will be supplied on the procedure for having the SRM/RTG calibrated.

Available accessories:

SFS-100 Conductive Rubber probes (set of 4)

BFS-100 1” Diameter Conductive Rubber Probes (set of 4)

6550-0011 Replacement Battery Pack (each SRM contains two battery packs)

6120-0035 Replacement Battery Charger for SRM

4000-0001 Carry Case

Please visit our website for details at www.pinionproducts.net

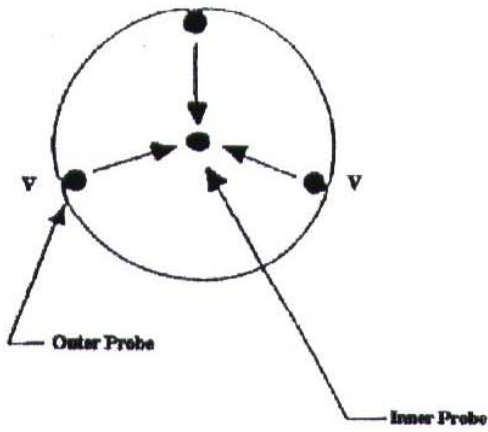

FIGURE 1

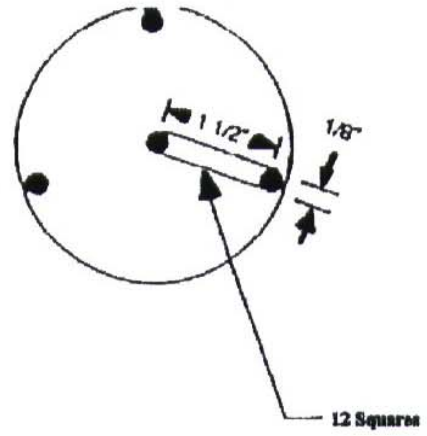

FIGURE 2

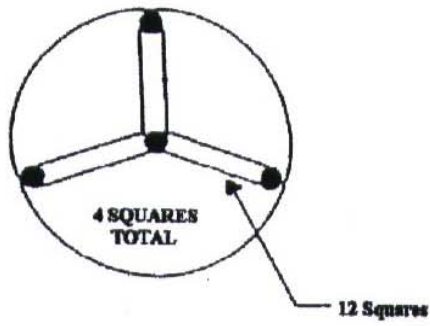

FIGURE 3

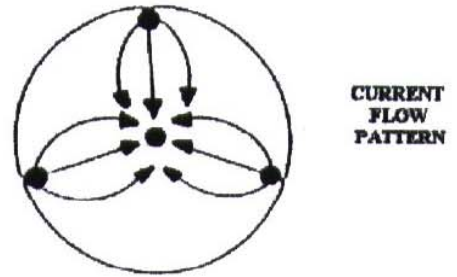

FIGURE 4

CURRENT
FLOW
PATTERN

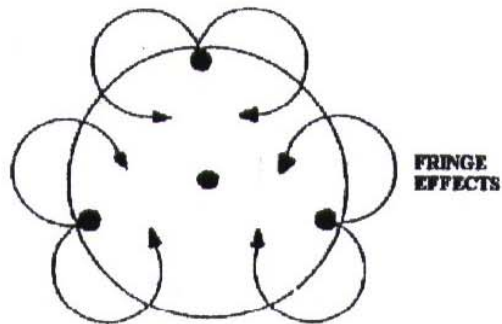

FIGURE 5