

Respond to the needs, " safe and comfortable "

SHOWA

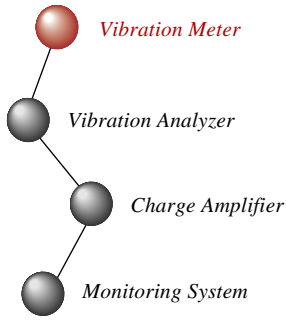

VIBROMETER WITH ANALYZER MINI VIBRO *Model-1022A*

Analog indication type vibrometer featuring compactness and high sensitivity.
Vibration frequency analysis using built-in tunable filter.
For measuring Vibration Severity.



VIBROMETER WITH ANALYZER MINI VIBRO

Model-1022A

Features

Compact and lightweight precision vibrometer for measuring vibrations of rotary machines, reciprocating machines, etc.

Applications include measurements of acceleration, velocity and displacement. MINI-VIBRO is most suitable for measuring very small vibrations.

Built-in frequency analyzing filter allows frequency analysis in a simple operation. Velocity measuring function is conformed to JIS B0907(ISO2954) "Standard for Vibration Severity Measuring Instrument".

Vibration pickup can be hand-held or fixed with screws (M10).

Optional magnet (MG-2) available for ease of fixing Pickup up.

Analog indication makes reading of fluctuating vibrations easier.

Composition

Mini vibro MODEL-1022A	1pc
Vibration pickup MODEL-2008	1pc
Contact pin	1pc
Pickup cable 1m CA2411-1	1pc
Output cable 1m CA1311-1	1pc
Dry cell 006P(9V)	1pc
Carrying case	1pc
Instruction manual	1copy
Magnet holder(MG-2)	option

Specifications

Measurement full scale range(10dB step, 5ranges)	
Displacement range	10,30,100,300,1000 μ m P-P
Velocity range	1,3,10,30,100mm/s RMS
Acceleration range	0.3,1,3,10,30m/s ² PEAK
rectifier	True RMS
Indication	Acceleration...EQ Peak Velocity...True RMS Displacement...EQ P-P
Frequency range	10 ~ 1000Hz
Analysis filter	10 ~ 1000Hz Q=10
AC Output	\pm 1V/Full Scale
DC Output(option)	+ 1V/Full Scale
Accuracy	Within 3% on the amplitude measurement of sinusoidal wave 80Hz, 10mm/s RMS
Power supply	Dry cell 006P(9V)..... 1pc 16 hours or more continuous operation
Temperature range	Operation 0 ~ +50 Warehouse -20 ~ +70
Dimensions, weight	Mini Vibro(W)85 x(H)190 x(D)55mm 700g
	Pickup(H)72 x(Dia)30mm 140g
	Contact pin(L)55mm 20g
	Magnet holder(H)30 x(Dia)40mm 260g

Dimensions

Mini Vibro MODEL-1022A

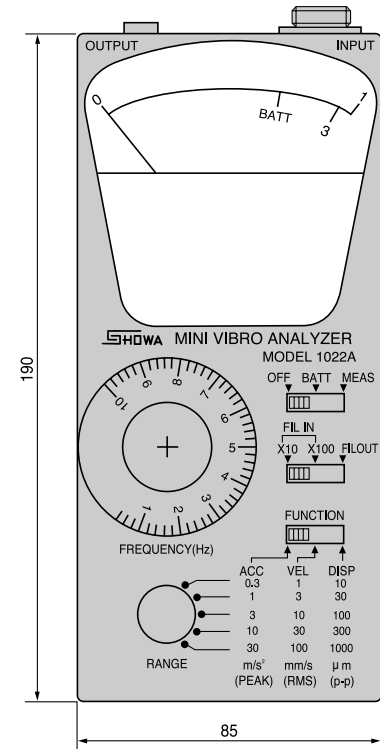

Pickup MODEL-2008

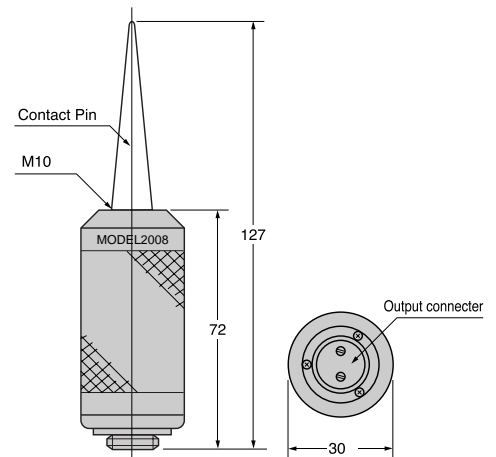

Unit: mm

SHOWA Respond to the needs; " safe and comfortable "

SHOWA SOKKI CORPORATION

Agent:

Head Office :

1

P

Factory :

1

P6

h