



**Product info sheet no. C 2.6 - „Light Version“
Humidity-/temperature sensors**

for use in air-conditioning systems, building services management systems and ventilation technology

Humidity

measuring range..... 0...100%rh
 sensing element capacitive FE09/4
 accuracy at 23°C (73,4°F) ±3 %RH (40...60%rh)
 at 23°C (73,4°F) ±5 %RH (otherwise)

working range 15...90%rh
 temperature effect typ. less 0.25%RH per °C/°F
 minimum air speed (only for PL,KL) 1m/sec, 3ft/sec
 Calibration 1 point

measuring medium
 air, pressureless, non-corrosive, non-condensing
 output 0...10V or 4...20mA

Temperature

measuring range..... 0...50°C (32...122°F)²⁾
 sensing element LM35
 accuracy (10...40°C ; 50...104°F) ±1 °C; ±1.8 °F
 calibration 1 point at 23°C
 output 0...10V or 4...20mA

Other data

power supply:

current output (KL) (PL) 12...24VDC
 load $\Omega = \frac{\text{supply} - 10 \text{ VDC}}{0,02 \text{ A}} \pm 50\Omega$

current output (WL) 15...30VDC
 max. load $\Omega = \frac{\text{supply} - 14 \text{ VDC}}{0,02 \text{ A}}$

voltage output 24V AC/DC ±10%
 voltage output (duct-version)
 15...30V DC/24V AC ±10%

load (voltage output only) >10kOhm
 ambient temperature KL,PL -20...+80°C (-4...176°F)
 WL -20...+60°C (-4...140°F)

electromagnetic compatibility

Emitted interference EN 55011 cl. B

Noise immunity EN 50082-2

sensor tube Ø20mm (Ø 0,79") aluminium

housing ABS light grey

protective system WL IP20

PL, KL (housing) IP54, sensor IP20

„subject to technical modifications“

Type variants Special types on request

Measured variable	Output	WL series wall	KL series duct	PL series rod-shaped
F rel. humidity	0...10 V	FWL2/5	FKL2/5	FPL2/5
	4...20 mA	FWL3/5	FKL3/5	FPL3/5
K r.h. + temperature	2 x 0..10 V	KWL2/5	KKL2/5	KPL2/5
	2 x 4..20 mA	KWL3/5	KKL3/5	KPL3/5
T temperature	0...10 V	TWL2/5	TKL2/5	TPL2/5
	4...20 mA	TWL3/5	TKL3/5	TPL3/5
	Pt100	TWL5/5	TKL5/5	TPL5/5
C r.h. + temp. passive	0...10V + T	CWL2/5-X	CKL2/5-X	CPL2/5-X
	4...20mA + T	CWL3/5-X	CKL3/5-X	CPL3/5-X
Weight		ca. 80g	ca. 330g	ca. 120g

Description

These sensors have been specially adapted to the needs of the ventilation and air-conditioning sector.

They come in three series (the WL series for wall mounting, the KL series for duct installation and the PL series with a cable for suspension from any location). The KL and PL series are equipped with gauze filters as standard. Other filters are available on request.

Use of capacitive humidity sensor elements is a guarantee of high long-term stability, resistance to dew formation, small hysteresis and good dynamic performance.

User instructions

Install these sensors at a place where characteristic climatic conditions occur. The wall-mounting sensors can be installed on flush-mounted sockets on installation systems and directly onto the wall. Avoid installing them close to heaters or windows or against outside walls.

The sensors with the connection cable can be suspended directly from the cable.

In principle, the sensors do not require any maintenance. However, the dynamic behaviour of the sensor may be affected if it is exposed to too much dust. In this case, clean the sensor element by blowing the dust off. In the case of the KL and PL series, clean the sensors by rinsing them carefully in distilled water. Never touch the highly sensitive sensor element.

Please consult the **application instructions** for the sensing elements (product info sheet no. A 1) or check with the manufacturer for further information which you need to bear in mind when using humidity sensors with capacitive sensing elements.

Other signal output temperature

NTC; PTC; KTY; LMx35; Pt100; Pt1000; Ni1000; AD592; LM34; BALKO 1kΩ; SILICON 2kΩ;
 SEMICONDUCTOR 559 mVDC @23°C (73,4°F)
 Thermistors @ 25°C (77°F) 1,8kΩ; 2,252kΩ; 3kΩ; 5kΩ; 10kΩ; 1,8kΩ (Type II; III, CSI); 20kΩ; 100kΩ

⚠ The electrical connection must only be carried out by properly qualified personnel.

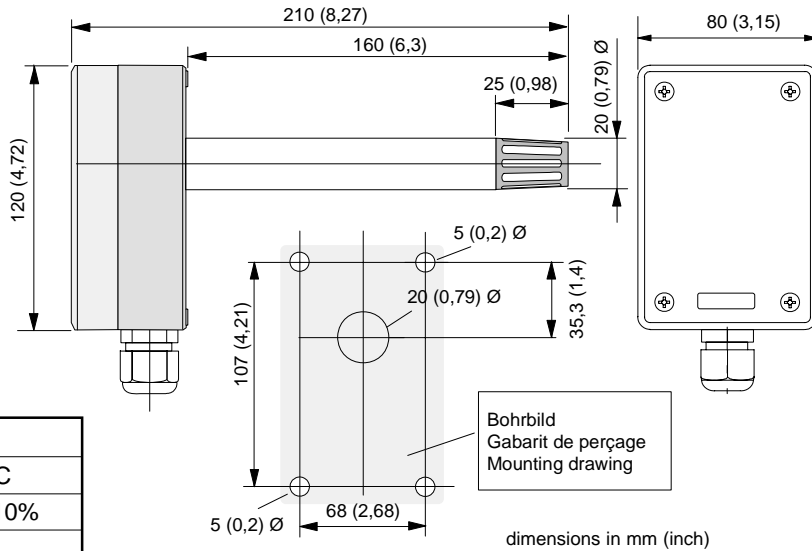

Connection diagram series KL

version **0...10VDC**

	terminals	ranges
supply	(1-) (2+)	15...30VDC
	(1~) (2~)	24 V AC ±10%
„humidity“	(3) (4+)	0...10VDC
„temperature“	(5) (6+)	0...10VDC
not galvanic disconnected		
negative pole (1-) (3) (5) = common		
„temperature“	(5) (6)	passive sensor galvanic disconnected
shield	(7)	

version **4...20mA, 12...24VDC (heed load)**

	terminals	ranges	Outputs galvanic disconnected
„humidity“	(1-) (2+)	4...20mA	
„temperature“	(3-) (4)	4...20mA	
„temperature“	(3) (4)	passive sensor	
shield	(5)		

Connection diagram series WL

version **0...10VDC**

	terminals	ranges
supply	(1-) (2+)	24 VDC ±10%
	(1~) (2~)	24 VAC ±10%
„humidity“	(3) (4+)	0...10VDC
„temperature“	(5) (6+)	0...10VDC
not galvanic disconnected		
negative pole (1-) (3) (5) = common		
„temperature“	(5) (6)	passive sensor galvanic disconnected

version **4...20mA, 15...30VDC (heed max. load)**

	terminals	ranges	Outputs galvanic disconnected
„humidity“	(1-) (2+)	4...20mA	
„temperature“	(3-) (4)	4...20mA	
„temperature“	(3) (4)	passive sensor	

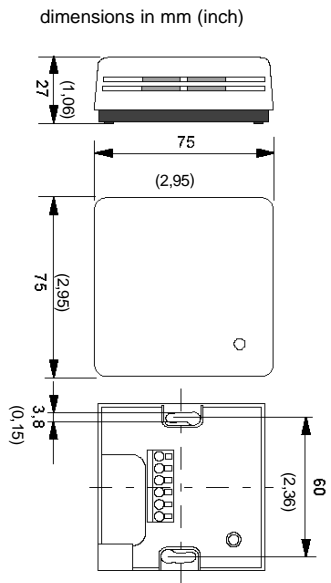

Connection diagram series PL

version **0...10VDC**

not galvanic disconnected
negative pole (-brown) = common

	wire colour	ranges
supply	(-brown) (+green)	15...30VDC
	(~brown)(~green)	24 V AC ±10%
„humidity“	(-brown) (+white)	0...10VDC
„temperature“	(-brown) (+yellow)	0...10VDC
„temperature“	(blue) (yellow)	passive sensor galvanic disconnected

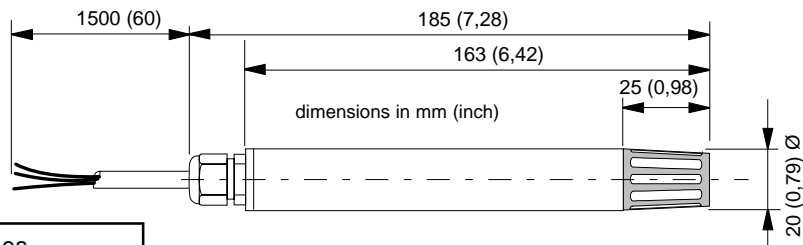

version **4...20mA, 12...30VDC (heed load)**

	wire colour	ranges	Outputs galvanic disconnected
„humidity“	(-green) (+brown)	4...20mA	
„temperature“	(-white) (+yellow)	4...20mA	
„temperature“	(white) (yellow)	passive sensor	